

Facility

28,000 ft² Building with Overhead Bridge Cranes

Mills

CNC Vertical Machining Centers

- (1) Doosan 16 x 30
- (1) Doosan 20 x 40
- (1) Fadal 60 x 30
- (2) Fadal 40 x 20
- (1) Mazak 20 x 65
- (1) Wasino 18 x 30
- (1) Doosan DHP5500 CNC Horizontal Machining Center 31" x 27" x 29" w/ Pallet Changer
- (1) KT Horizontal Data Mill 700 60"x24" 40 hp
- (1) Carlton Horizontal Mill 360" x 72"
- (2) CNC Vertical Mills 12 x 20
- (6) Bridgeport style vertical mills
- (4) Vertical mills size 2 to 4
- (3) Horizontal mills

Lathes

- (1) Samsung PL 35 CNC Turning Center
 - 16.0" max turning dia
 - 64.0" max turning length
- (1) Mazak MS250 CNC Turning Center
 - Automatic Bar Feed
 - Subspindle with milling
 - 11.0" max turning dia
 - 22.0" max turning length
 - 2.5" max bar dia
- (1) Mori Seiki NL2500 CNC Turning Center
 - Subspindle with milling and Y axis
 - 14.0" max turning dia
 - 51.1" max turning length
 - 3.1" max bar dia
- (1) Tsugami BN20 CNC Swiss Turning Center
 - High Speed Production Parts
 - Automatic Bar Feed
 - Subspindle with milling
 - 0.787" max turning dia
- (1) Doosan TT1800SY CNC Turning Center
 - Twin Turret Turning Center w/ Live Tools
 - Automatic Bar Feed
 - Subspindle with milling and Y axis
 - 9.05" max turning dia
 - 9.10" max turning length
 - 2.63" max bar dia
- 6) Manual lathes up to 36" swing x 120" length

Wire EDM

- (6) Fanuc Wire Edm's 14.6" x 21.7" x 12" 4 axis w/ Submerged Tanks

Grinders

- (4) Surface grinders up to 14" x 72"
- (1) Blanchard grinder 34"
- (1) Cylindrical grinder 14" x 60"

Saws

- (1) Vertical Bandsaw
- (2) Doall automatic horizontal bandsaw
- (1) Vertical bandsaw 24" x 24" capacity

Brake & Shear

- (1) 3/8" x 12' shear
- (1) 3/8 x 6' shear
- (1) 8' box and pan brake

Inspection

Mitutoyo BN1015 CNC Controlled CMM 40" x 60"
George Products Optical Automatic Smart Inspection System (OASIS)

Computer System

- (3) AutoCAD Workstations
- (2) Solidworks 3D Design Workstations
- (8) MasterCAM Workstations
- (1) EdgeCAM Workstations

Miscellaneous

CNC RAM EDM
30" J&L comparator
Radial arm drill
60 ton press
Tig and mig welding equipment
Paint booth 14' x 20'
Pressure washers
Steam cleaner
Sandblaster
Beadblaster
Dual Chamber Heat Treat Oven
Black Oxide Processing Unit

BG Machine, Inc.

2990 New Haven Road
Bardstown, KY 40004
Phone: 502-348-9061
Fax: 502-348-7002
Cage Code: 517V8
www.bgmachineinc.com

BG MACHINE



BG Machine, Inc.

QUALITY TOOLING, MACHINING, FABRICATION, AND CUSTOM MACHINERY

BG Machine, Inc., founded in 1980 in rural central Kentucky, has established itself as an industry leader in the design and manufacturing of industrial tooling and equipment. Skilled designers and craftsmen, with years of experience, manufacture production tools and machinery necessary for industries to stay competitive in today's fast paced, high-tech environment.

State of the art CAD/CAM, wire EDM, CNC milling, and CNC turning as well as numerous manual operations all play an important part in the tooling and machinery manufacturing process. BG Machine, Inc. also offers excellent support and service for the products it manufactures. The dedicated staff works closely with customers to insure complete satisfaction.

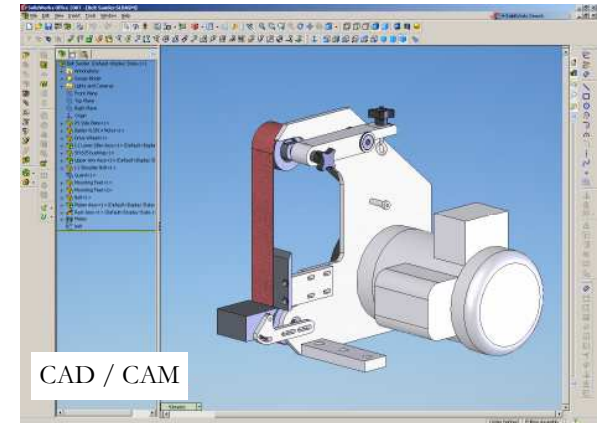

CAD / CAM



CNC Turning



Wire EDM

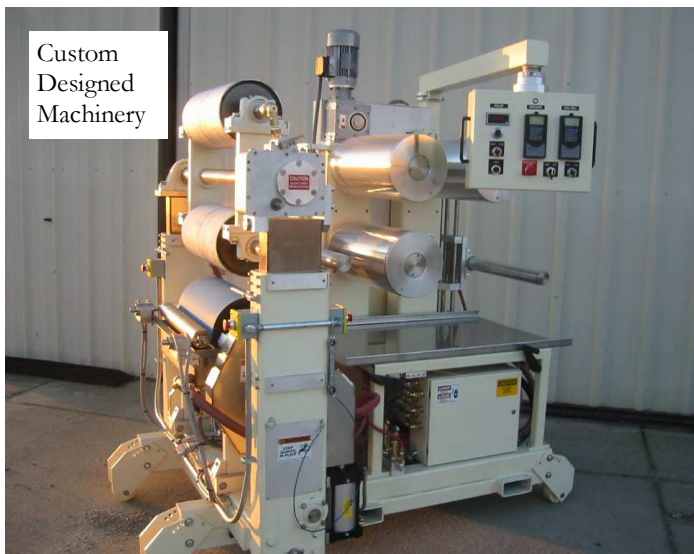

Custom
Designed
Machinery



Specialty Tooling



CNC Milling